

# GQHA

GEORGIA QUARTER  
HORSE ASSOCIATION

## **NOVICE/L1 SHOW**

### **Saturday**

### **May 16, 2026**

## **PATTERN BOOK**

# GQHA

GEORGIA QUARTER  
HORSE ASSOCIATION

**THANK YOU!!**

**We couldn't put on this show without you!**

**SERIES HIGHPOINT SADDLE SPONSORS**

**Clint Ainsworth Show Horses (Ron Corder Legacy Saddle) – Level 1 Youth**

**Dean Bogart Performance Horses – Level 1 Amateur**

**JM Performance Horses – Open Breed Youth**

**The Hoof House – Open Breed**

**SERIES HIGHPOINT HEADSTALL SPONSORS**

**Wynn Leather Company**

**DAILY HIGH POINT SPONSORS**

**BUCKLE SPONSORS**

**Blue Ribbon Performance Horses – Open, Amateur, Youth Ranch Trail**

# GQHA NOVICE SERIES

## Showmanship EWD, Small Fry (EWD (walk only))

Show Date:

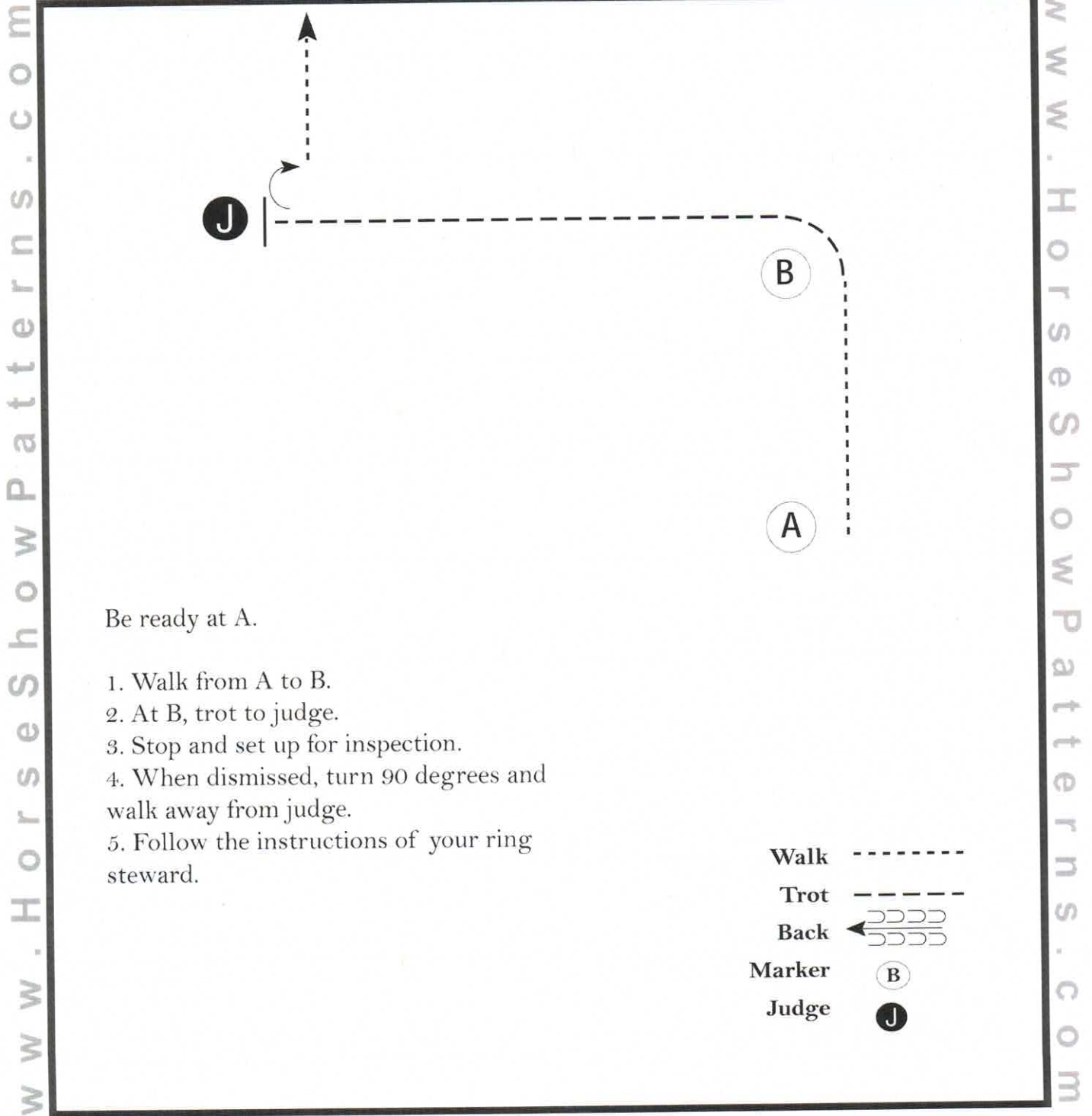

[S/WT-11]

Pattern Provided by:  
**YOUR JUDGES**

# GQHA NOVICE SERIES

Showmanship - Rookie, L1, Youth, Am, Open

Show Date:

www.HorseShowPatterns.com

www.HorseShowPatterns.com

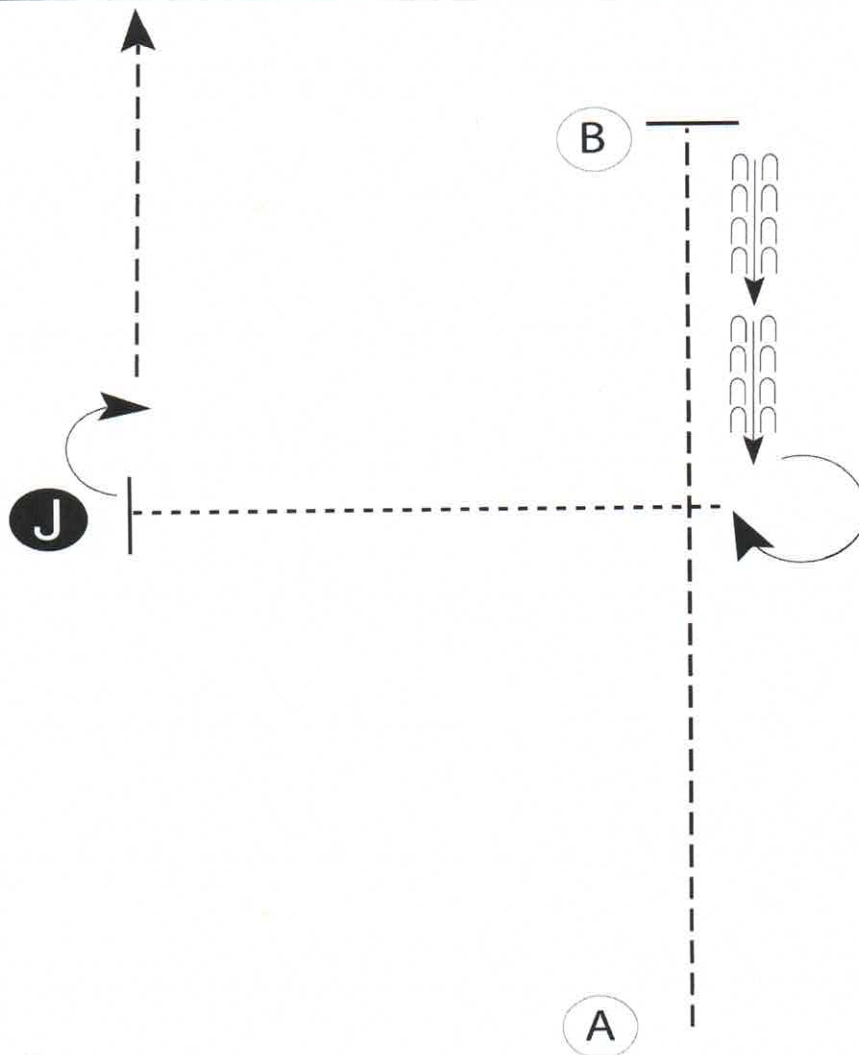

1. Trot A to B.
2. Stop at B.
3. Back halfway to A.
4. Perform a 270 degree turn .
5. Walk to the judge, stop and set up for inspection.
6. When dismissed, perform a 90 degree turn and trot away from judge.

Walk -----  
Trot - - - - -  
Back ← - - - - -  
Marker (B)  
Judge (J)

Follow the instructions of your ring steward.

[S/WT-1]

Pattern Provided by:  
**YOUR JUDGES**

# GQHA NOVICE SERIES

## Horsemanship - All Walk/Trot

Show Date:

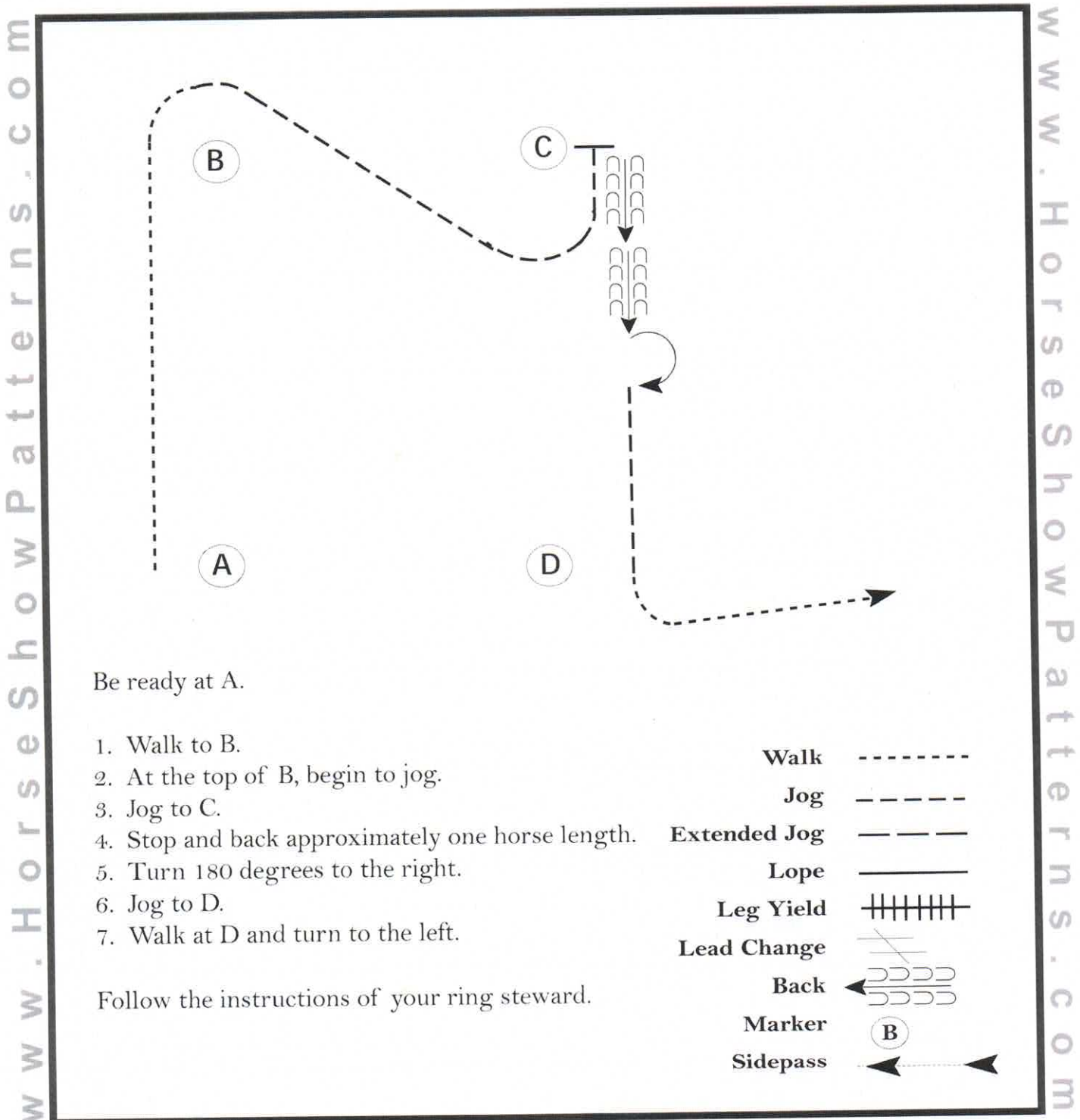

Be ready at A.

1. Walk to B.
2. At the top of B, begin to jog.
3. Jog to C.
4. Stop and back approximately one horse length.
5. Turn 180 degrees to the right.
6. Jog to D.
7. Walk at D and turn to the left.

Follow the instructions of your ring steward.

Walk	-----
Jog	- - - - -
Extended Jog	— — — —
Lope	—————
Leg Yield	
Lead Change	↘ /
Back	← C C C C ← C C C C
Marker	⊙ B
Sidepass	← — — — — →

[WH/WT-52]

Pattern Provided by:  
**YOUR JUDGES**

# GQHA NOVICE SERIES

## Horsemanship - All WJL

Show Date:

www.HorseShowPatterns.com

www.HorseShowPatterns.com

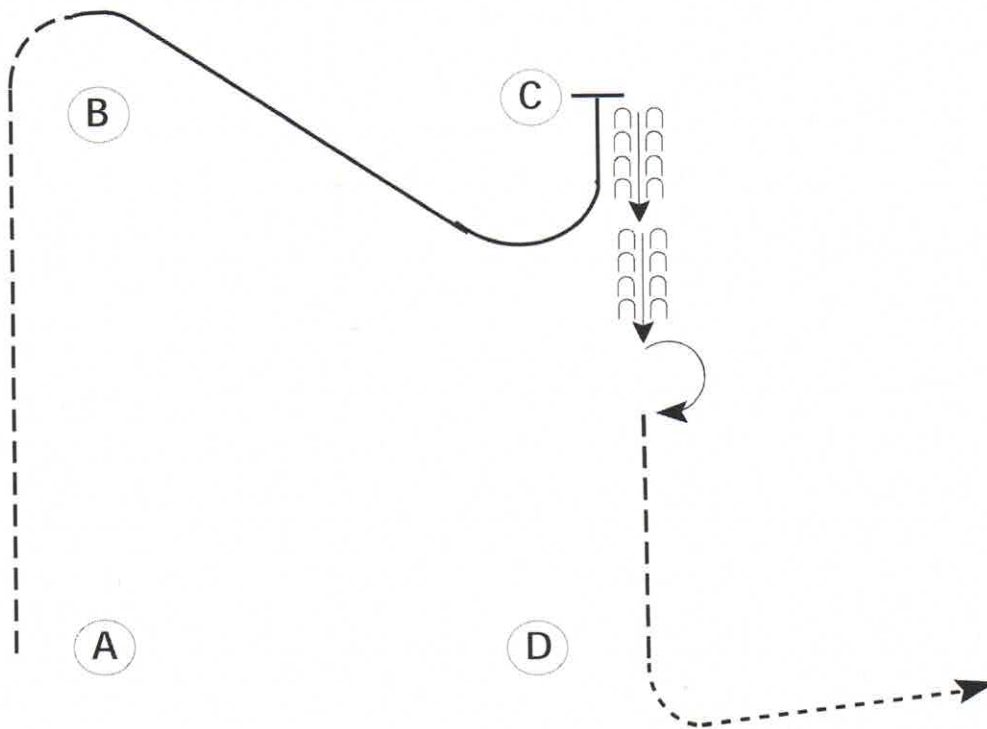

Be ready at A.

1. Jog to B.
2. At the top of B, pick up the left lead.
3. Lope on the left lead to C.
4. Back approximately one horse length.
5. Turn 180 degrees to the right.
6. Jog to D.
7. Walk at D and turn to the left.

Follow the instructions of your ring steward.

Walk	-----
Jog	- - - - -
Extended Jog	— — — —
Lope	—————
Leg Yield	
Lead Change	— / —
Back	← C C C C ← C C C C
Marker	⊙ B
Sidepass	← — — — — →

[WH/1-52]

**Pattern Provided by:**  
**YOUR JUDGES**

# GQHA NOVICE SERIES

## Equitation - All Walk Trot

Show Date:

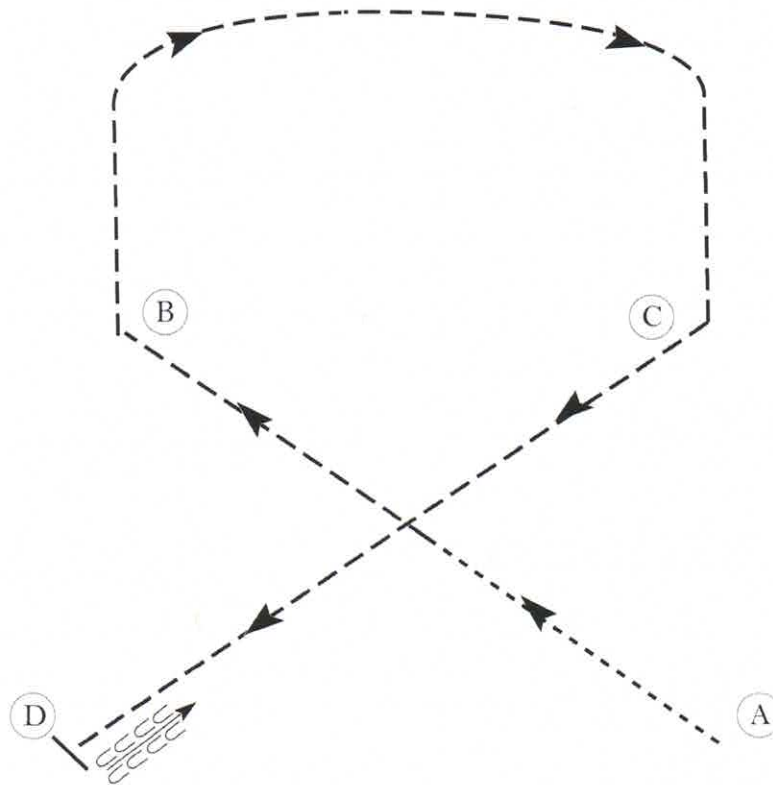

Be ready at A.

1. Walk 1/2 way to B.
2. Posting trot on the left diagonal to B.
3. Sitting trot to C.
4. Posting trot on the right diagonal 1/2 way to D.
5. Sitting trot to D.
6. Halt at D and back approximately one horse length.

Exit at a sitting trot.

Walk	-----
Trot	- - - - -
Extended Trot	-----
Canter	-----
Leg Yield	
Lead Change	↙ ↘
Back	←←←←←
Marker	Ⓚ
Sidepass	←←
Hand Gallop	-----

[HSE/WT-23]

Pattern Provided by:  
**YOUR JUDGES**

# GQHA NOVICE SERIES

## Equitation - All WTC

Show Date:

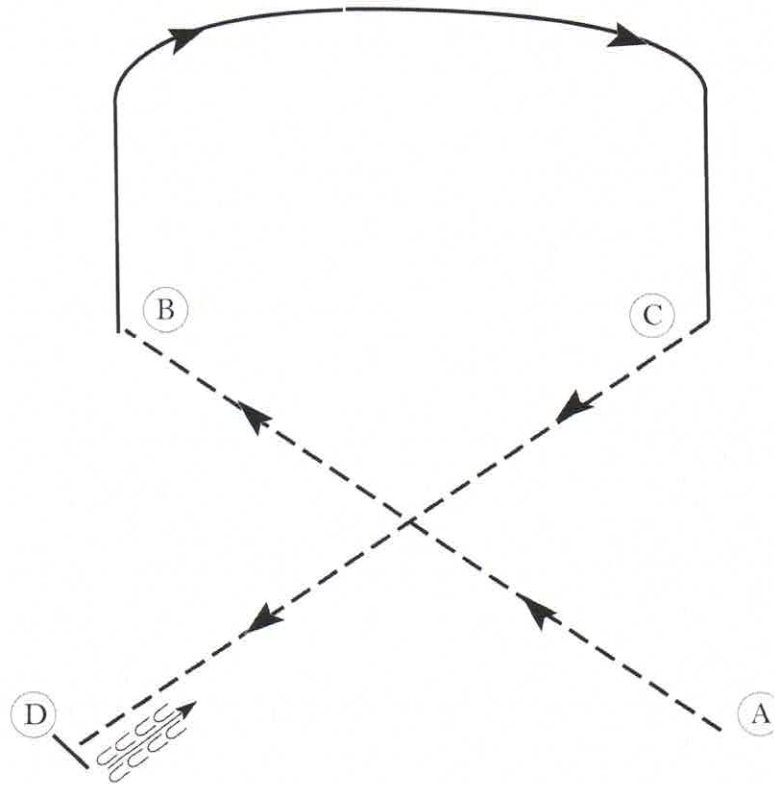

Be ready at A.

1. Posting trot on the left diagonal to B.
2. Canter right lead to C.
3. Posting trot on the right diagonal 1/2 way to D.
4. Sitting trot to D.
5. Halt at D and back approximately one horse length.

Exit at a sitting trot.

Walk	-----
Trot	- - - - -
Extended Trot	— — — — —
Canter	—————
Leg Yield	
Lead Change	↙ ↘
Back	←←←←←
Marker	(B)
Sidepass	← — — — — →
Hand Gallop	— — — — —

[HSE/1-23]

Pattern Provided by:  
**YOUR JUDGES**

# ALL TRAIL

(Walk-Trot - Jog where lope is shown)

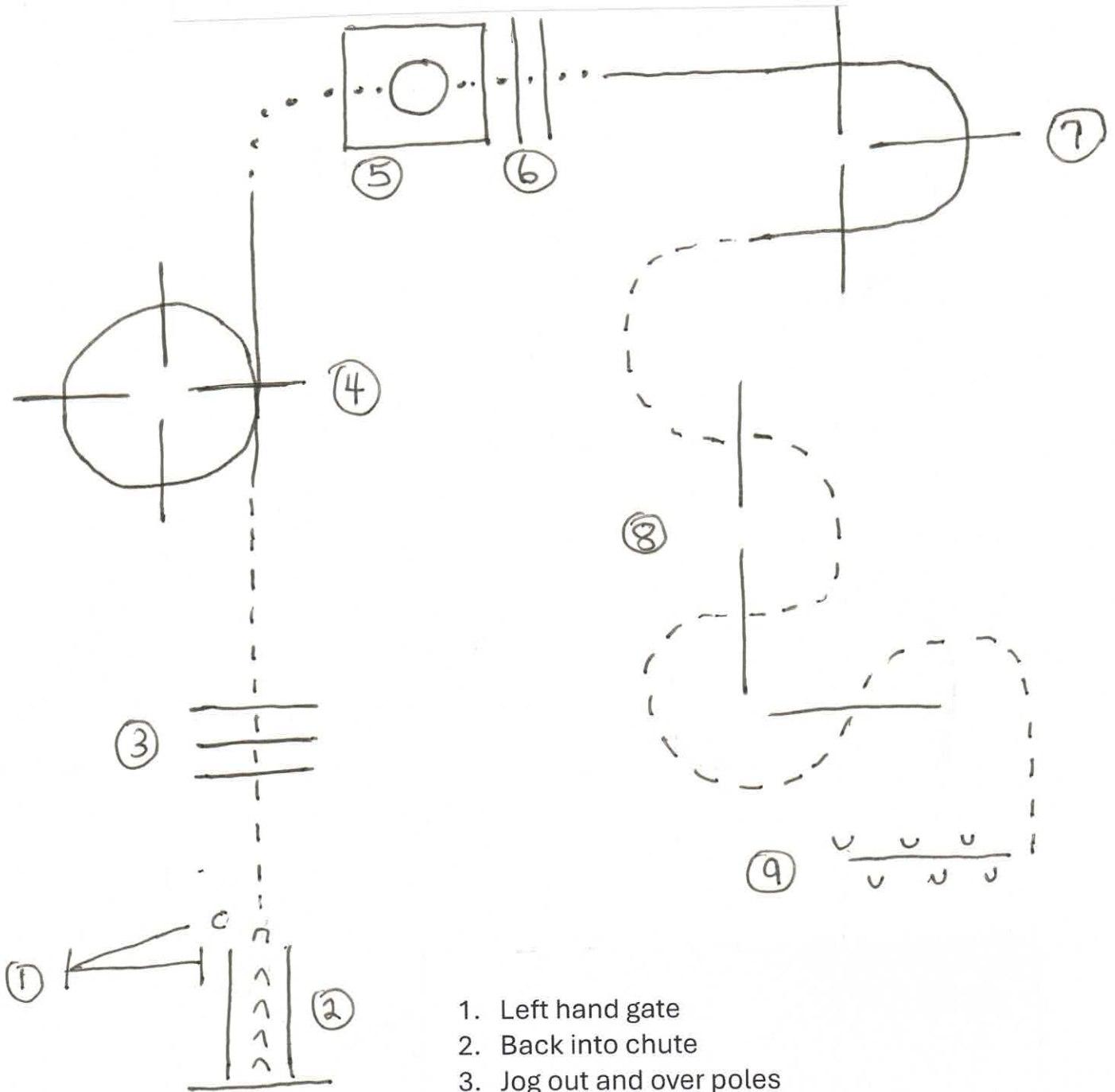

1. Left hand gate
2. Back into chute
3. Jog out and over poles
4. Left lead over poles  
(Walk-Trot - Jog where lope is shown)
5. Walk into box, 360 either direction
6. Walk out and over poles
7. Right lead over poles  
(Walk-Trot - Jog where lope is shown)
8. Jog serpentine over poles
9. Sidepass right

# RANCH RIDING - PATTERN 12

## LEGEND

.....	Walk
...	Extended Walk
- - -	Trot
- - - -	Extended Trot
—	Lope
— — —	Extended Lope
////	Back
//	Lead Change

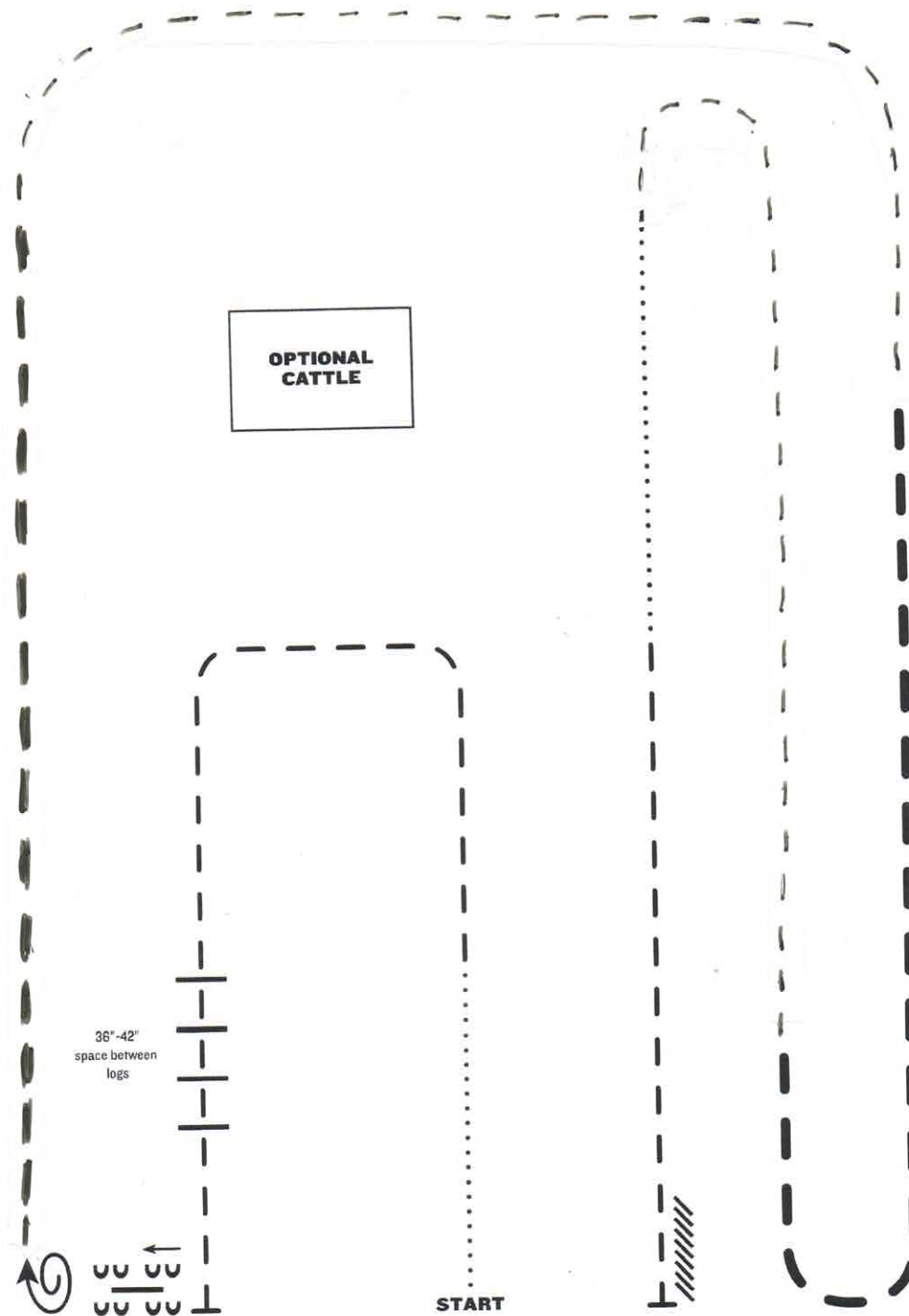

1. Walk
2. Trot
3. Trot over logs, stop
4. Side pass right over log
5. 1/2 turn right
6. Extended lope right lead
7. Lope right lead
8. Extended trot
9. Lope left lead
10. Walk
11. Trot
12. Stop and back

Note: The drawn description of this pattern is only intended for the general depiction of the pattern. Exhibitors should utilize the arena space to best exhibit their horses.

# RANCH RIDING - PATTERN 12

## LEGEND

.....	Walk
...	Extended Walk
- - -	Trot
- - - -	Extended Trot
—	Lope
— — —	Extended Lope
////	Back
\\	Lead Change

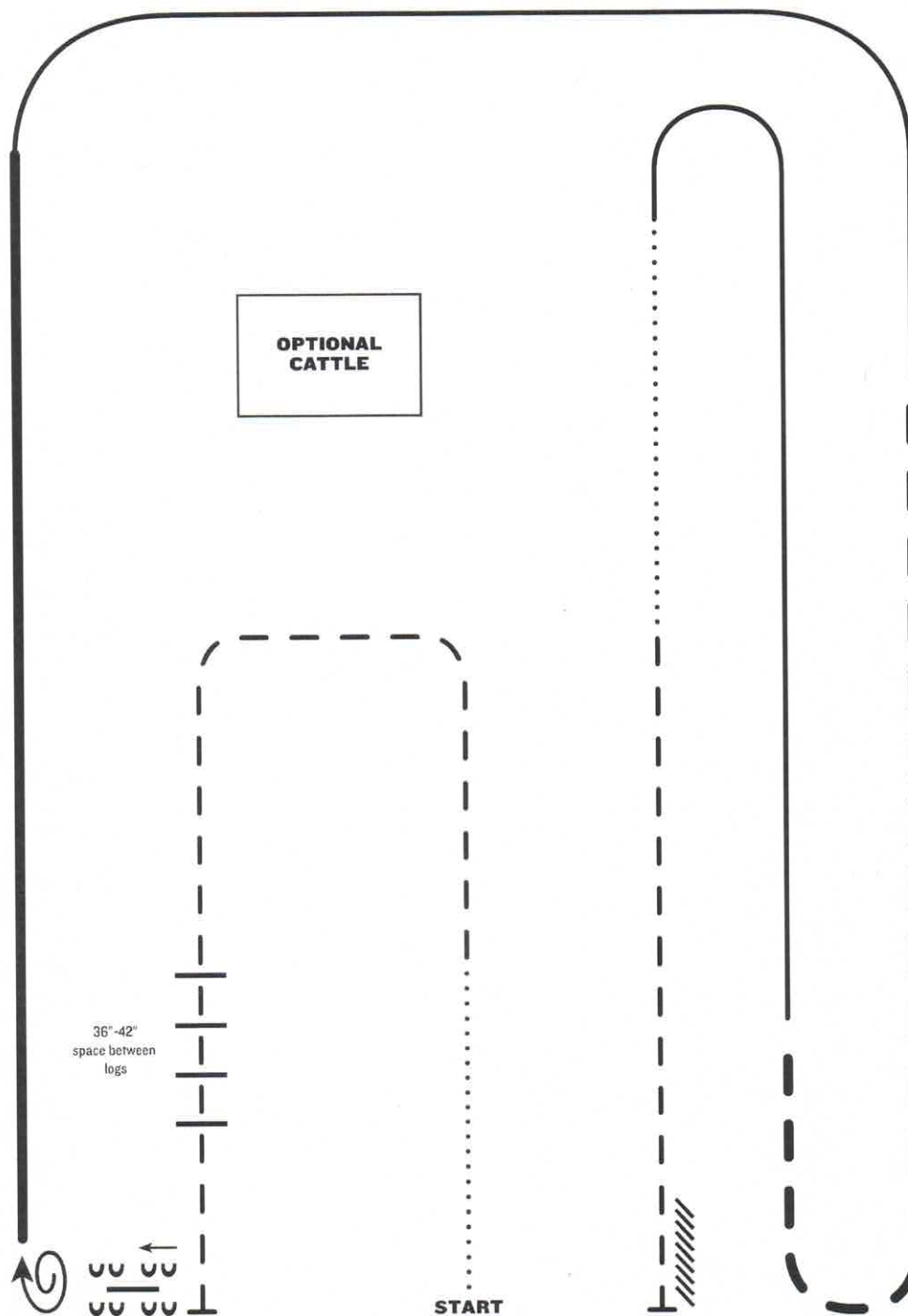

OPTIONAL  
CATTLE

36"-42"  
space between  
logs

START

1. Walk
2. Trot
3. Trot over logs, stop
4. Side pass right over log
5. 1 1/2 turn right
6. Extended lope right lead
7. Lope right lead
8. Extended trot
9. Lope left lead
10. Walk
11. Trot
12. Stop and back

Note: The drawn description of this pattern is only intended for the general depiction of the pattern. Exhibitors should utilize the arena space to best exhibit their horses.

# REINING PATTERN B

Approved only for Level I Youth & Amateur, Youth 13 & Under

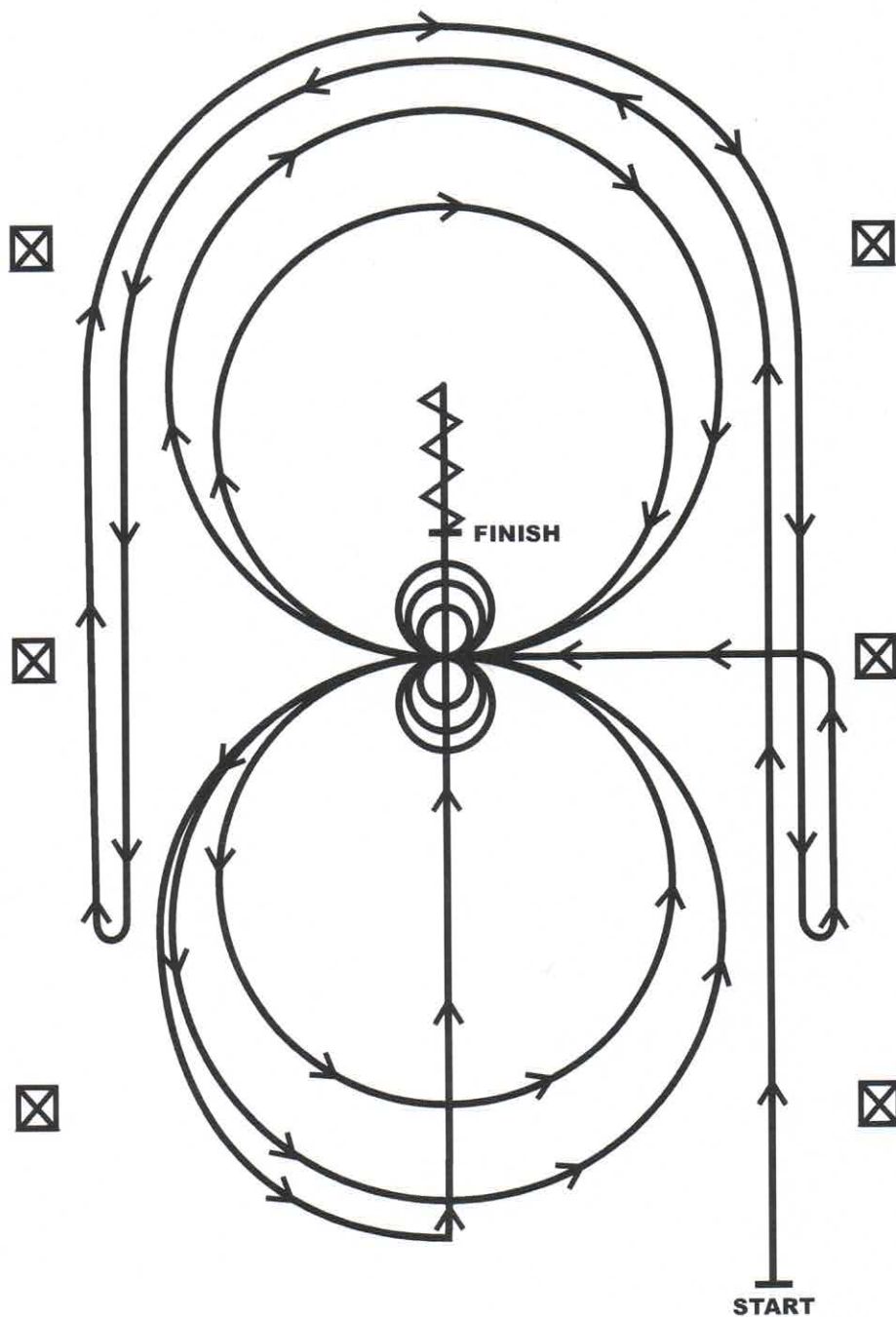

1. Beginning, lope straight up the right side of the arena, circle the top of the arena run straight down the opposite or left side of the arena past the center mark and do a right rollback—no hesitation.
2. Continue straight up the left side of the arena circle back around the top of the arena run straight down the right side of the arena past the center marker and do a left rollback—no hesitation.
3. Continue up the right side of the arena to the center marker, at the center marker the horse should be on the left lead and complete two circles to the left, one large fast and one small slow. Stop at center
4. Complete three spins to the left. Hesitate.
5. Complete two circles to the right, one large fast and one small slow. Stop at center.
6. Complete three spins to the right. Hesitate.
7. Begin a large circle to the left, do not close the circle. Continue up the center of the arena past the center marker and do a sliding stop.
8. Back up at least ten feet. Hesitate to demonstrate completion of the pattern.

WALK TROT

# Ranch Trail

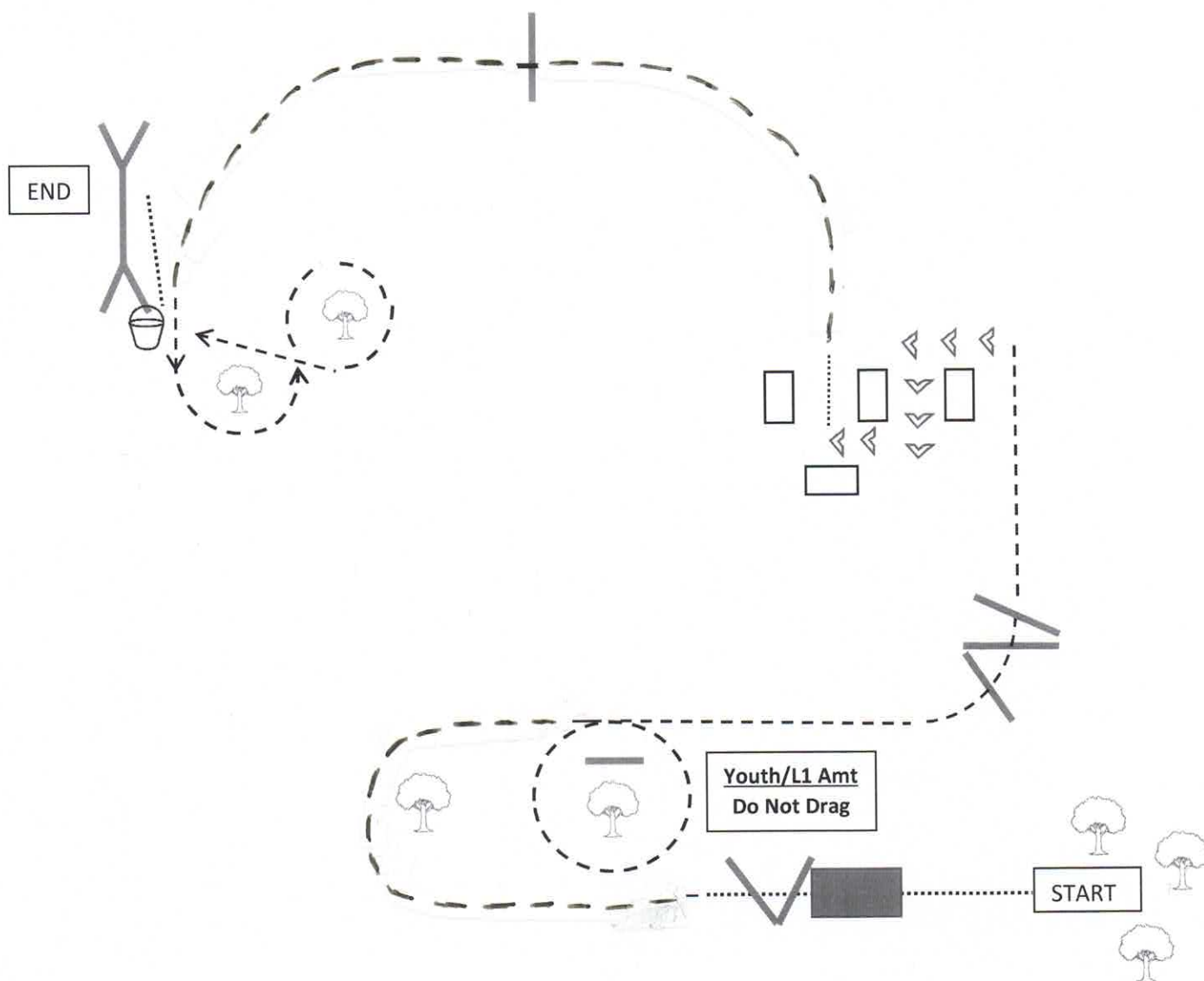

1. Extend walk over bridge and logs
2. Extend trot
3. Trot around drag
4. Trot over logs
5. Sidepass, back, sidepass and walk out
6. Extend trot over log
7. Pick up bucket and extend trot through obstacle – return bucket
8. Work left hand gate to exit

# Ranch Trail

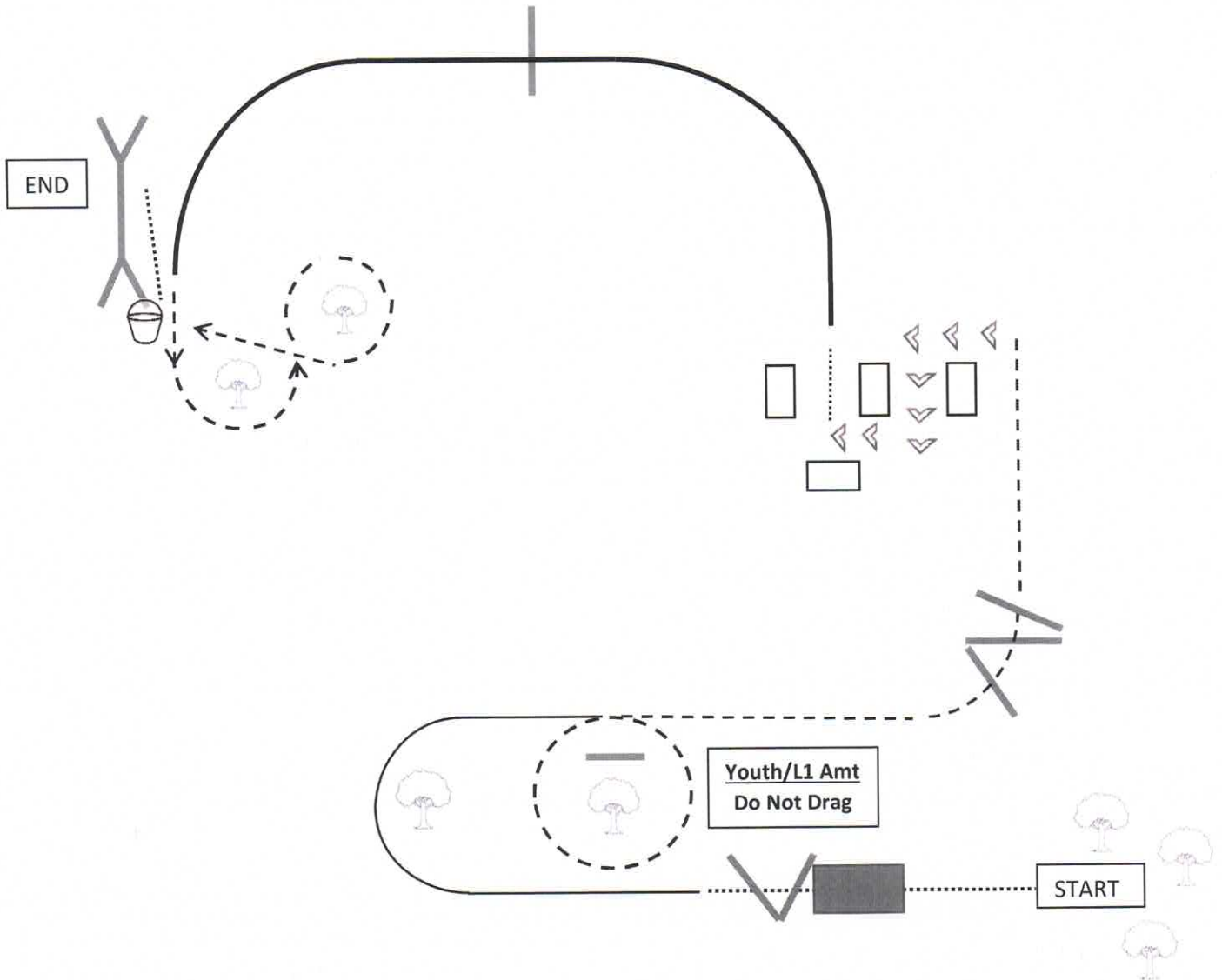

1. Extend walk over bridge and logs
2. Lope right lead
3. Drag (L1 Amt and Youth trot around drag)
4. Trot over logs
5. Sidepass, back, sidepass and walk out
6. Extend lead lead over log
7. Pick up bucket and extend trot through obstacle – return bucket
8. Work left hand gate to exit